

POONA COUPLINGS PVT. LTD.

Industrial Range PM Couplings

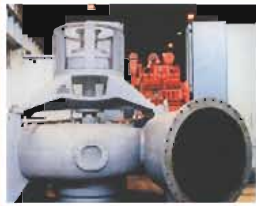

The Correct Solution

PM Features And Benefits



POONA COUPLINGS have been leaders in the design and manufacture of flexible couplings for over 20 years. with the following capabilities:

- Approved to ISO 9001:2000
- Total quality system
- Latest CAD technology
- Torsional vibration analysis
- Transient and finite element analysis

Applications

- Metal manufacture
- Mining and mineral processing
- Pumps
- Fans
- Compressors
- Cranes and hoists
- Pulp and paper industry
- General heavy duty industrial applications

Features

- Severe shock load protection
- Intrinsically fail safe
- Maintenance free
- Vibration control
- Zero backlash
- Misalignment capability
- Low cost

Construction details

- PM Couplings up to PM 40 are made out of special grade of S.G. Iron. Couplings from PM 60 to PM 600 are made of steel casting
- Separate rubber elements with a choice of grade and hardness, styrene butadiene with 60 shore hardness (Sm60) being the standard.
- Rubber elements loaded in compression.
- Rubber elements are totally enclosed.

Benefits

- Giving protection and avoiding failure of the driveline under high transient torques.
- Ensuring continuous operation of the driveline in the unlikely event of rubber failure or damage.
- With no lubrication or adjustment required resulting in low running costs.
- Achieving low vibratory loads in the driveline components by selection of optimum stiffness characteristics.
- Eliminating torque amplifications through pre compression of the rubber elements.
- Allows axial and radial misalignment between the driving and driven machines.
- The PM Coupling gives the lowest lifetime cost.

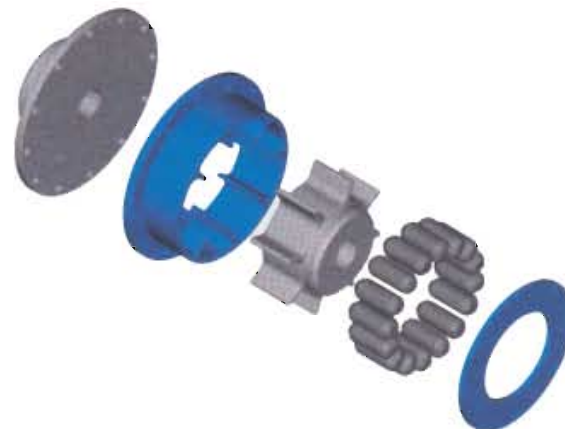

PM Shaft To Shaft PM 0.4 To PM 60

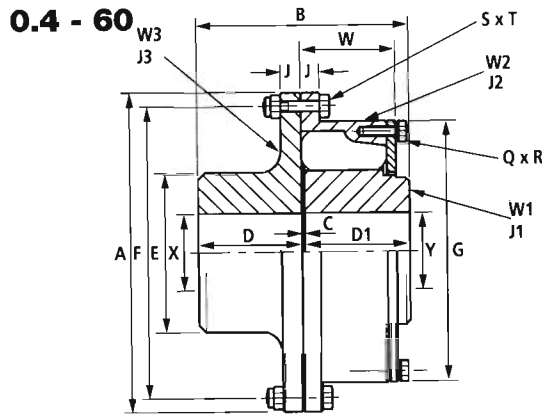

Dimensions, Weight, Inertia and Alignment

COUPLING SIZE		0.4	0.7	1.3	3	6	8	12	18	27	40	60
DIMENSIONS (mm)	A	161.9	187.3	215.9	260.3	260	302	338	392	440	490	568
	B	103	110	130	143	175	193	221.5	254	290.5	329	377.5
	C	1	2	2	3	3	3	3.5	4	4.5	5	5.5
	D	51	54	64	70	86	95	109	125	143	162	186
	D1	51	54	64	70	86	95	109	125	143	162	186
	E	76	92	108	122	135	148	168	195	220	252	288
	F	146	171.4	196.8	235	240	276	312	360	407	458	528
	G	133	157	181	221	222	245	280	320	367	418	479
	J	9.5	11	12	14.5	11	13.5	14	16	18.5	21	24
	Q	5	5	6	6	8	8	8	8	8	8	8
	R	M8	M8	M8	M8	M8	M10	M12	M16	M16	M16	M20
	S	8	8	8	8	12	12	12	12	12	16	12
	T	M8	M8	M8	M8	M8	M12	M12	M16	M16	M16	M20
	W	36	39	46	60	81	89	102	118	134	152.7	175
	MAX. X&Y (4)	41	51	64	73	85	95	109	125	143	162	186
	MIN. X (5)	27	27	35	37	50	62	68	80	90	105	120
	MIN. Y	27	27	37	40	50	55	65	70	85	105	110
RUBBER ELEMENTS	Per Cavity	1	1	1	1	1	1	1	1	1	1	1
	Per Coupling	10	10	12	12	16	16	16	16	16	16	16
MAXIMUM SPEED (rpm) (1)		7200	6300	5400	4500	4480	3860	3450	2975	2650	2380	2050
WEIGHT(3) (kg)	W1	1.9	2.8	4.5	6.9	8.9	11.62	17.74	27.0	40.18	59.5	89.45
	W2	2.0	2.9	4.6	6.0	6.55	10.92	15.86	24.59	35.34	50.47	77.80
	W3	2.8	4.3	6.6	10.0	10.84	15.14	21.24	33.03	47.80	69.32	104.63
	TOTAL	6.7	10.0	15.7	22.9	26.3	37.7	54.8	84.6	123.3	179.3	271.9
INERTIA(3)	J1	0.002	0.004	0.008	0.018	0.026	0.050	0.101	0.203	0.392	0.756	1.491
	J2	0.006	0.014	0.019	0.049	0.072	0.149	0.273	0.560	1.041	1.898	3.867
	J3	0.005	0.013	0.025	0.05	0.058	0.116	0.194	0.406	0.748	1.345	2.719
ALLOWABLE MISALIGNMENT(2)												
	RADIAL (mm)	0.8	0.8	0.8	1.2	1.5	1.6	1.6	1.6	1.9	2.1	2.4
	AXIAL(mm)	0.8	1.2	1.2	1.2	1.25	1.5	1.75	2.0	2.25	2.5	2.75
	CONICAL (degree)	0.5	0.5	0.5	0.5	0.5	0.5	0.5	0.5	0.5	0.5	0.5

- (1) For operation above 80% of the declared maximum coupling speed, it is recommended that the coupling is dynamically balanced.
- (2) Installations should be initially aligned as accurately as possible, In order to allow for deterioration in alignment over time, it is recommended that initial alignment should not exceed 25% of the above noted data. The forces on the driving and driven machinery should be calculated to ensure that these do not exceed the manufacturers allowables.
- (3) Weights and inertias are calculated with mean bore for couplings.
- (4) Oversize shafts can be accommodated in large boss driving flanges, manufactured to customer's requirements.
- (5) PM0.4 - PM3 driving flanges are available with solid bores on request.

PM Shaft To Shaft PM 90 To PM 600

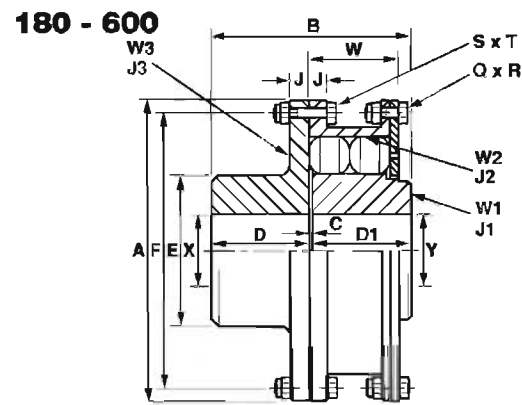
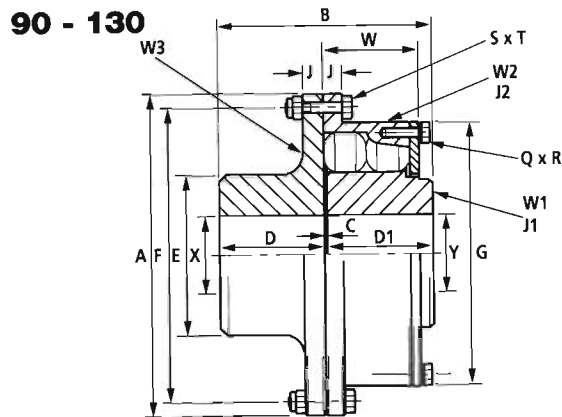

Dimensions, Weight, Inertia and Alignment

COUPLING SIZE		90	130	180	270	400	600
DIMENSIONS (mm)	A	638	728	798	925	1065	1195
	B	432.5	487	544	623	710.5	812
	C	6.5	7	8	9	10.5	12
	D	213	240	268	307	350	400
	D1	213	240	268	307	350	400
	E	330	373	415	475	542	620
	F	598	680	750	865	992	1122
	G	548	620	-	-	-	-
	J	26.5	31	33.5	36	43	52
	Q	8	8	12	12	12	24
	R	M20	M24	M24	M30	M36	M36
	S	16	16	20	20	20	24
	T	M20	M24	M24	M30	M36	M36
	W	200	226	252	288.5	328	376
	MAX. X&Y (4)	213	240	268	307	350	400
MIN. X (5)	140	160	167	182	232	285	
MIN. Y	140	160	170	195	235	285	
RUBBER ELEMENTS	Per Cavity	2	2	2	2	2	2
	Per Coupling	32	32	32	32	32	32
MAXIMUM SPEED (rpm) (1)		1830	1600	1460	1260	1090	975
WEIGHT(3) (kg)	W1	132.0	191.11	262.3	389.0	562.4	813.3
	W2	111.96	165.24	266.78	414.0	633.4	909.1
	W3	151.78	222.39	297.4	437.3	651.2	946.7
	TOTAL	395.7	578.7	826.5	1240.3	1847	2669.1
INERTIA(3)	J1	2.872	5.330	9.14	17.88	34.03	65.54
	J2	7.188	13.680	28.80	59.30	119.5	220.2
	J3	4.955	9.565	15.35	29.89	60.66	115.7
ALLOWABLE MISALIGNMENT(2)							
RADIAL (mm)		2.8	3.3	3.5	3.9	4.6	5.2
AXIAL(mm)		3.25	3.5	4.0	4.5	5.25	6.0
CONICAL (degree)		0.5	0.5	0.5	0.5	0.5	0.5

- (1) For operation above 80% of the declared maximum coupling speed, it is recommended that the coupling is dynamically balanced.
- (2) Installations should be initially aligned as accurately as possible, In order to allow for deterioration in alignment over time, it is recommended that initial alignment should not exceed 25% of the above noted data. The forces on the driving and driven machinery should be calculated to ensure that these do not exceed the manufacturers allowables.
- (3) Weights and inertias are calculated with mean bore for couplings.
- (4) Oversize shafts can be accommodated in large boss driving flanges, manufactured to customer's requirements.

PM Mill Motor Couplings

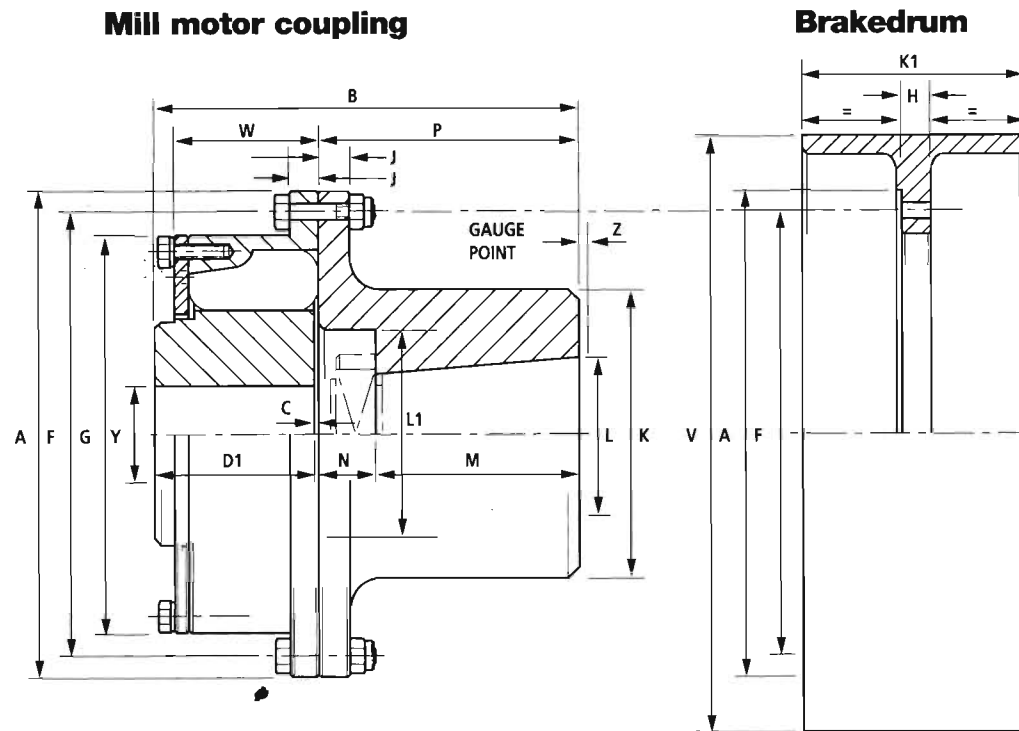

Brakedrums may be used in conjunction with the whole range of PM couplings and may be bolted on either the driving flange or flexible half side of the coupling, the recess - $\varnothing A$ - locating on the outside diameter of the coupling.

Recommended brake drums for each size of coupling are shown in the table, but $\varnothing V$ is adjustable to suit "Non-standard" applications.

Type PM-SDW Dimensions Table (Ingot Motor)

COUPLING SIZE		0.7	1.3	3	6	12	18				
MOTOR FRAME SIZE		180M	180L	225L	250L	280M	280L	355L	400L	400LX	450L
hp		12.7	16	26	43	63	82	123	170	228	300
rpm		956	958	730	732	734	735	590	590	591	592
DIMENSIONS (mm)	A	187.3	187.3	215.9	260.3	260	260	338	338	392	392
	B	168	168	178	215	231	231	284.5	324.5	341	341
	C	2	2	2	3	3	3	3.5	3.5	4	4
	D1	54	54	64	70	86	86	109	109	125	125
	F	171.4	171.4	196.8	235	240	240	312	312	360	360
	G	157	157	181	221	222	222	280	280	320	320
	H	15.3	20.3	18.7	18.9	23.5	23.5	23.5	25.5	26	26
	J	11	11	12	14.5	11	11	14	14	16	16
	K	100	100	125	140	155	185	205	205	205	215
	K1	90	110	110	140	180	180	180	225	225	225
	L	42	42	55	60	75	75	95	100	100	110
	L1	70	70	90	105	120	120	135	155	155	170
	M	84	84	84	107	107	107	132	167	167	167
	N	28	28	28	35	35	35	40	45	45	45
	P	112	112	112	142	142	142	172	212	212	212
	V	250	315	315	400	500	500	500	630	630	630
W	36	46	46	60	81	81	102	102	118	118	
MIN.Y	27	27	38	49	50	50	72	72	80	80	
MAX.Y	51	51	64	73	85	85	109	109	125	125	
Z	3	3	3	3	3	3	3	5	5	5	

The motor ratings are taken for periodic Duty Classes S4 and S5, 150 starts per hour with a cyclic duration factor at 40% For motors operating outside these ratings, consult Poona Couplings.

PM Mill Motor Couplings

Type PM - mm Dimensions Table (AISE Motor)

Series 6 Mill Motors

COUPLING SIZE		0.4	0.7	1.3	3	6	12	18	27	40				
MOTOR FRAME SIZE		602	603	604	606	608	610	612	614	616	618	620	622	624
hp		7	10	15	25	35	50	75	100	150	200	275	375	500
rpm		800	725	650	575	525	500	475	460	450	410	390	360	340
DIMENSIONS (mm)	A	161.9	187.3	187.3	215.9	260.3	260	338	338	392	440	440	440	490
	B	153	172	172	196	219	237	281.5	281.5	318	336.5	336.5	392.5	466
	C	1	2	2	2	3	3	3.5	3.5	4	4.5	4.5	4.5	5
	D1	51	54	54	64	70	86	109	109	125	143	143	143	162
	F	146	171.4	171.4	196.8	235	240	312	312	360	407	407	407	458
	G	133	157	157	181	221	222	280	280	320	367	367	367	418
	H	13.5	15.3	15.3	18.7	18.9	18.5	18.5	18.5	21	21	21	21	21
	J	9.5	11	11	12	14.5	11	14	14	16	18.5	18.5	18.5	21
	K	102	121	121	133	171	178	190	216	241	254	305	305	305
	K1	83	95	95	146	146	171	222	222	286	286	286	286	286
	L	44.45	50.80	50.80	63.50	76.20	82.55	92.07	107.95	117.47	127.00	149.22	158.75	177.80
	L1	76.2	88.9	88.9	101.6	123.8	127	158.7	158.7	181	203.2	228.6	228.6	228.6
	M	70	83	83	95	111	111	124	124	137	149	168	178	232
	N	31	33	33	35	35	37	45	45	52	40	51	67	67
	P	101	116	116	130	146	148	169	169	189	189	219	245	299
	V	203	254	254	330	330	406	483	483	584	584	584	584	584
	W	36	39	39	46	60	81	102	102	118	134	134	152.7	152.7
	MIN.Y	22	27	27	38	49	50	72	72	80	92	92	92	105
	MAX.Y	41	51	51	64	73	85	109	109	125	143	143	143	162
Z	3	3	3	3	3	3	3	3	5	5	5	5	5	

Series 8 Mill Motors

COUPLING SIZE		0.4	0.7	1.3	3	6	12	18	27			
MOTOR FRAME SIZE		802	802	803	804	806	808	810	812	814	816	818
hp		7.5	10	15	20	30	50	70	100	150	200	250
rpm		800	800	725	650	575	525	500	475	460	450	410
DIMENSIONS (mm)	A	161.9	161.9	187.3	215.9	260.3	260.3	260	338	338	392	440
	B	153	153	172	182	203	219	237	281.5	281.5	318	336.5
	C	1	1	2	2	3	3	3	3.5	3.5	4	4.5
	D1	51	51	54	64	70	70	86	109	109	125	143
	F	146	146	171.4	196.8	235	235	240	312	312	360	407
	G	133	133	157	181	221	221	222	280	280	320	367
	H	13.5	15.3	15.3	18.7	18.9	18.5	18.5	18.5	18.5	21	21
	J	9.5	9.5	11	12	14.5	14.5	11	14	14	16	18.5
	K	102	102	121	121	133	171	178	190	216	241	254
	K1	83	95	95	146	146	171	171	222	222	286	286
	L	44.45	44.45	50.8	50.80	63.50	76.20	82.55	92.07	107.95	117.47	127.00
	L1	76.2	76.2	88.9	88.9	101.6	123.8	127	158.7	158.7	181	203.2
	M	70	70	83	83	95	111	111	124	124	137	149
	N	31	31	33	33	35	35	37	45	45	52	40
	P	101	101	116	116	130	146	148	169	169	189	189
	V	203	254	254	330	330	406	406	483	483	584	584
	W	36	36	39	46	60	60	81	102	102	118	134
	MIN.Y	22	22	27	38	49	49	50	72	72	80	92
	MAX.Y	41	41	51	64	73	73	85	109	109	125	143
Z	3	3	3	3	3	3	3	3	3	5	5	

PM Technical Data

1.1 Prediction of the System Torsional Vibration Characteristics.

An adequate prediction of the system torsional vibration characteristics can be made by the following method.

1.1.1 Use the torsional stiffness as shown in the technical data, which is based upon data measured at a 30°C ambient temperature (C_{Tdyn}).

1.1.2 Repeat the calculation made as 1.1.1 but using the maximum temperature correction factor S_{t100} and dynamic magnifier correction factor, M_{100} , for the corrected rubber. Use tables below to adjust values for both torsional stiffness and dynamic magnifier.
ie, $C_{Tdyn} = C_{Tdyn} \times S_{T100}$

Rubber Grade	Temp _{max} °C	S_t
SM 60	100	$S_{t100} = 0.60$
SM 70	100	$S_{t100} = 0.44$
SM 80	100	$S_{t100} = 0.37$
SM 60 is considered "standard"		

Rubber Grade	Dynamic Magnifier at 30°C (M_{30})	Dynamic Magnifier at 100°C (M_{100})
SM 60	8	13.1
SM 70	6	13.6
SM 80	4	10.8
SM 60 is considered "standard"		

1.1.3 Review calculations 1.1.1 and 1.1.2 and if the speed range is clear of criticals which do not exceed the allowable heat dissipation value as published in the catalogue, then the coupling is considered suitable for the application with respect to the torsional vibration characteristics. If there is a critical in the speed range then actual temperature of the speed range then actual temperature of the coupling will need to be calculated.

1.2 Prediction of the Actual Coupling Temperature and Torsional Stiffness

1.2.1 Use the torsional stiffness as published in the catalogue, this is based upon data measured at 30°C and the dynamic magnifier at 30°C (M_{30})

1.2.2 Compare the synthesis value of the calculated heat load in the coupling (Pk) at the speed of interest to the "Allowable Heat Dissipation" (Pkw).

The coupling temperature rise

$$^{\circ}\text{C} = \text{Temp}_{\text{coup}} = \left(\frac{Pk}{Pkw} \right) \times 70$$

The coupling temperature = ϑ

$$\vartheta = \text{Temp}_{\text{coup}} + \text{Ambient Temp.}$$

1.2.3 Calculate the temperature correction factor S_t from 1.3 (if the coupling temperature > 100°C, then use S_{t100}). Calculate the dynamic Magnifier as per 1.4. Repeat the calculation with the new value of coupling stiffness and dynamic magnifier.

1.2.4 Calculate the coupling temperature as per 1.2. Repeat calculation until the temperature agrees with the correction factors for torsional stiffness and dynamic magnifier used in the calculation.

1.3 Temperature Correction Factor

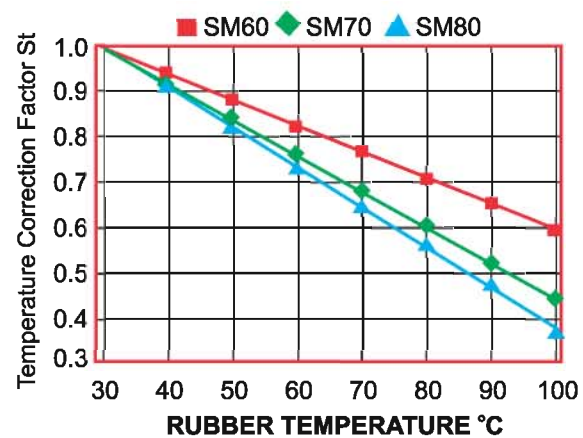

1.4 Dynamic Magnifier Correction Factor

The Dynamic Magnifier of the rubber is subject to temperature variation in the same way as the torsional stiffness.

$$M_T = \frac{M_{30}}{S_t}$$

$$\psi_T = \psi_{30} \times S_t$$

Rubber Grade	Dynamic Magnifier (M_{30})	Relative Damping ψ_{30}
SM 60	8	0.78
SM 70	6	1.05
SM 80	4	1.57
SM 60 is considered "standard"		

PM Technical Data - Standard Blocks

PM 0.4 - PM 60

COUPLING SIZE		0.4	0.7	1.3	3	6	8	12	18	27	40	60
kW/ rpm		0.045	0.07	0.14	0.32	0.63	0.84	1.25	1.89	2.83	4.19	6.28
MAXIMUM TORQUE T _{kmax} (kNm)		0.43	0.67	1.3	3.0	6.0	8.0	12.0	18.0	27.0	40.0	60.0
VIBRATORY TORQUE T _{kw} (kNm) (2)		0.054	0.084	0.163	0.375	0.75	1.0	1.5	2.25	3.375	5.0	7.5
ALLOWAABLE DISSIPATED HEAT AT AMB. TEMP. 30°C P _{kw} (W)		266	322	365	458	564	562	670	798	870	1018	1159
MAXIMUM SPEED (rpm)		7200	6300	5400	4500	4480	3860	3450	2975	2650	2380	2050
DYNAMIC TORSIONAL (3) STIFFNESS C _{Tdyn} (MNm/rad)												
@ 0.25 T _{KN}	SM 60	0.003	0.005	0.012	0.029	0.073	0.097	0.146	0.218	0.328	0.485	0.728
	SM 70	0.005	0.008	0.018	0.043	0.104	0.138	0.207	0.311	0.466	0.691	1.036
	SM 80	0.009	0.013	0.030	0.072	0.134	0.179	0.269	0.403	0.605	0.896	1.344
@ 0.50 T _{KN}	SM 60	0.005	0.008	0.019	0.046	0.104	0.138	0.207	0.311	0.466	0.691	1.036
	SM 70	0.007	0.010	0.025	0.058	0.139	0.185	0.277	0.416	0.624	0.924	1.386
	SM 80	0.010	0.015	0.036	0.086	0.181	0.241	0.361	0.542	0.813	1.204	1.806
@ 0.75 T _{KN}	SM 60	0.008	0.012	0.029	0.069	0.154	0.205	0.308	0.462	0.693	1.027	1.540
	SM 70	0.009	0.014	0.033	0.078	0.199	0.265	0.398	0.596	0.895	1.325	1.988
	SM 80	0.012	0.018	0.043	0.102	0.265	0.353	0.529	0.794	1.191	1.764	2.646
@ 1.0 T _{KN}	SM 60	0.0011	0.018	0.043	0.102	0.224	0.299	0.448	0.672	1.008	1.493	2.240
	SM 70	0.012	0.018	0.044	0.105	0.277	0.370	0.554	0.832	1.247	1.848	2.772
	SM 80	0.014	0.021	0.051	0.122	0.382	0.510	0.764	1.147	1.720	2.548	3.822
RADIAL STIFFNESS (N/mm) @ NO LOAD	SM 60	685	723	1240	2050	6276	6966	7980	9140	10460	11069	12680
	SM 70	1070	1130	1950	3240	8400	9320	10680	12230	14000	15960	18280
	SM 80	1740	1820	3210	5190	11400	12650	14500	16600	19000	21660	24810
RADIAL STIFFNESS (N/mm) @ 50% T _{kmax}	SM 60	1430	1510	2600	4300	13180	14630	16780	19200	21970	25050	28700
	SM 70	1760	1860	3200	5240	13800	15320	17550	20100	23000	26220	30040
	SM 80	2510	2650	4480	7450	16500	18320	20980	24000	27500	31350	35910
AXIAL STIFFNESS (N/mm) @ NO LOAD	SM 60	458	502	714	970	1060	1176	1347	1543	1766	2010	2306
	SM 70	753	828	1180	1640	2748	3050	3495	4000	4580	5220	5980
	SM 80	1040	1160	1670	2230	4120	4573	5240	6000	6867	7828	8968
AXIAL STIFFNESS (N/mm) @ 50% T _{kmax}	SM 60	920	1050	1540	2020	2300	2500	2920	3310	3830	4360	4980
	SM 70	1100	1360	1920	2610	2750	3050	3500	4000	4580	5220	5980
	SM 80	1250	1450	2060	2750	4120	4570	5240	6000	6870	7830	8970
MAX. AXIAL FORCE (N) @ 50% T _{kmax} (1)	SM 60	66	72	102	128	1501	1668	1913	2178	2502	2845	3267
	SM 70	78	80	112	140	1648	1825	2099	2374	2747	3139	3581
	SM 80	85	106	148	185	2237	2482	2845	3257	3728	4265	4866

- 1) The Couplings will 'slip' axially when the maximum axial force is reached.
- 2) At 10Hz only, allowable vibratory torque at higher or lower frequencies $f_e = T_{kw} \sqrt{\frac{10 \text{ Hz}}{f_e}}$
- 3) These values should be corrected for rubber temperature as shown in the design information section.

$$T_{KN} = \frac{T_{KMAX}}{3}$$

PM Technical Data - Standard Blocks

PM 90 - PM 600

COUPLING SIZE		90	130	180	270	400	600
kW/ rpm		9.43	13.62	18.86	28.29	41.91	62.86
MAXIMUM TORQUE T _{kmax} (kNm)		90.0	130.0	180.0	270.0	400.0	600.0
VIBRATORY TORQUE T _{kw} (kNm) (2)		11.25	16.25	22.5	33.75	50.00	75.00
ALLOWAABLE DISSIPATED HEAT AT AMB. TEMP. 30°C P _{kw} (W)		1209	1369	1526	1735	1985	2168
MAXIMUM SPEED (rpm)		1830	1600	1460	1260	1090	975
DYNAMIC TORSIONAL (3) STIFFNESS C _{Tdyn} (MNm/rad)							
@ 0.25 T _{KN}	SM 60	1.092	1.577	2.184	3.276	4.853	7.280
	SM 70	1.554	2.245	3.108	4.662	6.838	10.360
	SM 80	2.016	2.912	4.032	6.048	8.960	13.440
@ 0.50 T _{KN}	SM 60	1.554	2.245	3.108	4.661	6.838	10.360
	SM 70	2.079	3.003	4.158	6.237	9.240	13.860
	SM 80	2.709	3.913	5.418	8.127	12.040	18.060
@ 0.75 T _{KN}	SM 60	2.310	3.337	4.620	6.720	10.269	15.400
	SM 70	2.982	4.307	5.964	8.946	13.251	19.880
	SM 80	3.969	5.733	7.938	11.907	17.64	26.480
@ 1.0 T _{KN}	SM 60	3.360	4.853	6.720	10.080	14.931	22.400
	SM 70	4.158	6.006	8.316	12.474	18.480	27.720
	SM 80	5.733	8.281	11.466	17.199	25.480	38.220
RADIAL STIFFNESS (N/mm) @ NO LOAD	SM 60	14500	16400	18270	20920	23820	27300
	SM 70	20916	23646	26350	30170	34340	39370
	SM 80	28200	32100	35750	40945	46600	53400
RADIAL STIFFNESS (N/mm) @ 50% T _{kmax}	SM 60	32820	37110	41350	47350	53890	61780
	SM 70	34360	38850	43290	49560	56420	64680
	SM 80	41100	46450	51760	59260	67460	77330
AXIAL STIFFNESS (N/mm) @ NO LOAD	SM 60	2638	2980	3324	3800	4332	4966
	SM 70	6840	7740	8620	9870	11230	12880
	SM 80	10260	11600	12924	14800	16844	19310
AXIAL STIFFNESS (N/mm) @ 50% T _{kmax}	Sm60	5720	6460	7200	8240	9380	10760
	SM 70	6840	7740	8620	9870	11230	12880
	SM 80	10260	11600	12920	14800	16840	19310
MAX. AXIAL FORCE (N) @ 50% T _{kmax} (1)	SM 60	3728	4218	4709	5396	6131	7034
	SM 70	4101	4640	5160	5915	6730	7720
	SM 80	5572	6298	7014	8025	9143	10477

- 1) The Couplings will 'slip' axially when the maximum axial force is reached.
- 2) At 10Hz only, allowable vibratory torque at higher or lower frequencies $f_e = T_{kw} \sqrt{\frac{10 \text{ Hz}}{f_e}}$
- 3) These values should be corrected for rubber temperature as shown in the design information section.

$$T_{KN} = \frac{T_{KMAX}}{3}$$

PM Technical Data - Special Round Blocks

PM 12 - PM 600

COUPLING SIZE		12	18	27	40	60	90	130	180	270	400	600
kW/ rpm		1.25	1.89	2.83	4.19	6.28	9.43	13.62	18.86	28.29	41.91	62.86
NORMAL TORQUE T _{kw} (kNm)		3.2	4.8	7.2	10.67	15.99	24.00	34.67	48.0	72.0	106.67	159.99
MAXIMUM TORQUE T _{kmax} (kNm) (2)		12.0	18.0	27.0	40.0	60.0	90.0	130.0	180.0	270.0	400.0	600.0
VIBRATORY TORQUE T _{kw} (kNm) (2)		1.0	1.5	2.25	3.334	5.0	7.5	10.833	15.0	22.5	29.0	42.75
ALLOWAABLE DISSIPATED HEAT AT AMB. TEMP. 30°C P _{kw} (W)		130	150	180	220	260	300	340	375	440	490	565
MAXIMUM SPEED (rpm)		3450	2975	2650	2380	2050	1830	1600	1460	1260	1090	975
DYNAMIC TORSIONAL (3) STIFFNESS C _{Tdyn} (MNm/rad)												
@ 0.25 T _{KN}	SM 60	0.053	0.08	0.12	0.18	0.27	0.613	0.885	1.226	1.839	2.724	4.087
	SM 70	0.072	0.109	0.163	0.241	0.362	0.895	1.293	1.79	2.685	3.978	5.967
	SM 80	0.1	0.149	0.224	0.322	0.498	0.747	1.079	1.493	2.24	3.319	4.98
@ 0.50 T _{KN}	SM 60	0.088	0.132	0.198	0.293	0.44	0.791	1.143	1.582	2.373	3.516	5.273
	SM 70	0.104	0.155	0.233	0.345	0.52	1.05	1.517	2.1	3.15	4.667	7
	SM 80	0.159	0.239	0.358	0.53	0.796	1.193	1.724	2.387	3.58	5.304	7.956
@ 0.75 T _{KN}	SM 60	0.168	0.251	0.377	0.559	0.84	1.154	1.667	2.308	3.462	5.129	7.693
	SM 70	0.162	0.243	0.364	0.539	0.809	1.317	1.902	2.634	3.951	5.853	8.78
	SM 80	0.214	0.321	0.481	0.713	1.069	1.603	2.316	3.207	4.81	7.126	10.689
@ 1.0 T _{KN}	SM 60	0.285	0.427	0.641	0.948	1.424	1.91	2.759	3.82	5.73	8.489	12.733
	SM 70	0.256	0.385	0.577	0.855	1.282	1.85	2.672	3.7	5.55	8.222	12.333
	SM 80	0.328	0.491	0.737	1.092	1.638	2.457	3.549	4.913	7.37	10.919	16.378
RADIAL STIFFNESS (N/mm) @ NO LOAD	SM 60	2619	3000	3433	3914	4497	5132	5798	6464	7398	8438	9657
	SM 70	3742	4286	4905	5592	6425	7333	8284	9236	10570	12050	13798
	SM 80	6138	7030	8044	9170	10538	12025	13586	15147	17335	19770	22628
RADIAL STIFFNESS (N/mm) @ T _{kn}	SM 60	9510	10900	12470	14215	16300	18640	21000	23480	26870	30650	35070
	SM 70	9056	10374	11870	13530	15550	17745	20048	22350	25580	29176	33390
	SM 80	9132	10460	11968	13644	15678	17892	20214	22535	25790	29410	33666
AXIAL STIFFNESS (N/mm) @ NO LOAD	SM 60	1122	1285	1470	1675	1925	2198	2482	2768	3168	3613	4135
	SM 70	1495	1710	1960	2234	2568	2930	3310	3690	4220	4818	5514
	SM 80	2545	2915	3335	3800	4368	4986	5632	6278	7187	8197	9380
AXIAL STIFFNESS (N/mm) @ T _{KN}	SM 60	2918	3340	3825	4360	5010	5718	6460	7200	8242	9400	10750
	SM 70	3067	3510	4020	4580	5266	6000	6790	7570	8660	9880	11300
	SM 80	3218	3686	4218	4808	5526	6306	7124	7942	9090	10368	11865
MAX. AXIAL FORCE (N) @ T _{KN} (1)		2943	3335	3728	4415	5003	5690	6475	7161	8240	9418	10791

- 1) The ouplings will 'slip' axially when the maximum axial forve is reached.
- 2) At 10Hz only, allowable vibratory torque at higher or lower frequencies $f_e = T_{kw} \sqrt{\frac{10 \text{ Hz}}{f_e}}$
- 3) These values should be corrected for rubber temperature as shown in the design information section.

PM Design Variations

The PM Coupling can be adapted to meet customer needs as can be seen from some of the design variations shown below. For a more comprehensive list contact Renold Hi-Tec.

Torque Limiting Coupling

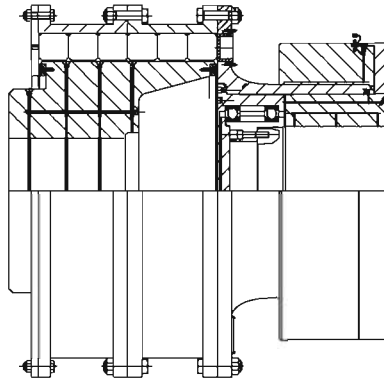

Combination with a torque limiting device to prevent damage to driving and driven machine under shock load.

Brake Disk Coupling

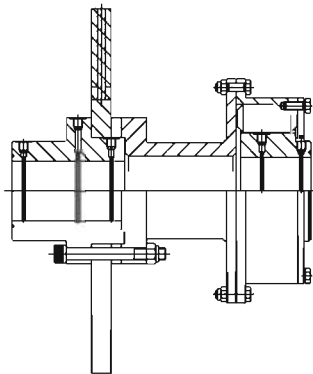

Combination with a brake disc, for use on cranes, fans and conveyor drives. (Brake drum couplings also available.)

Cardan Shaft Coupling

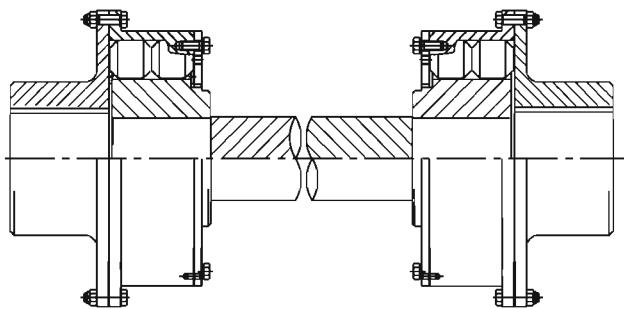

Cardan Shaft Coupling. Used to increase the distance between shaft ends and give a higher misalignment capability.

Vertical Spacer Coupling

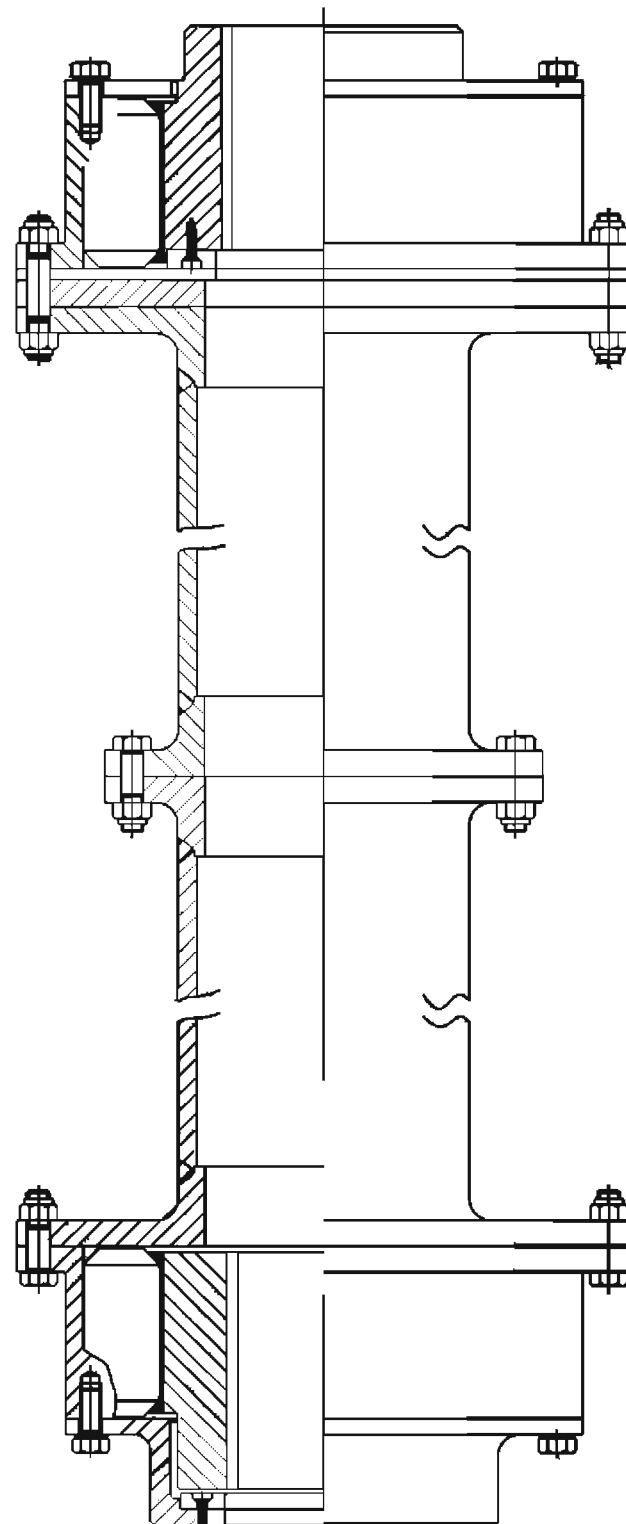

Spacer Couplings. Used increase the distance between shaft ends and allow access to driven and driving machine.

PM Design Variations

The PM coupling range can be adapted to meet customer needs. Below are some of the arrangements that have been produced.

For a more comprehensive list contact Poona Couplings

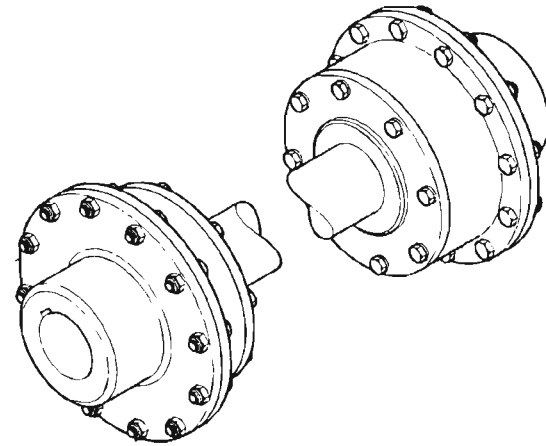
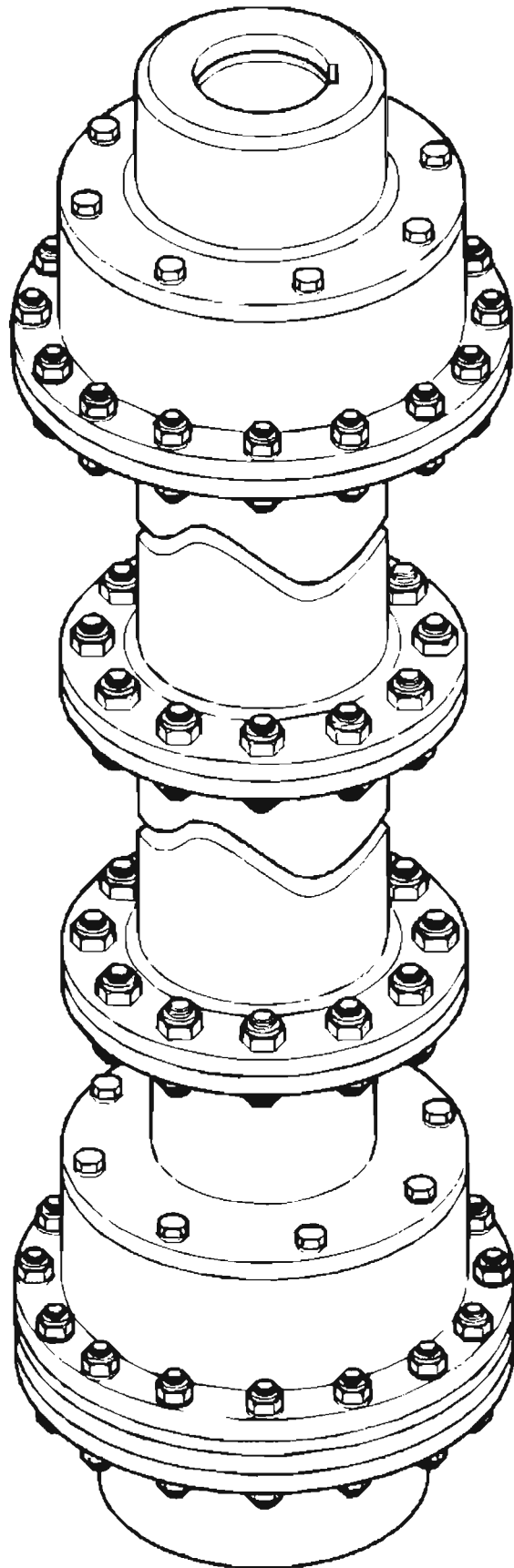

Cardan shaft coupling used to increase the distance between shaft ends and give a higher misalignment capability.

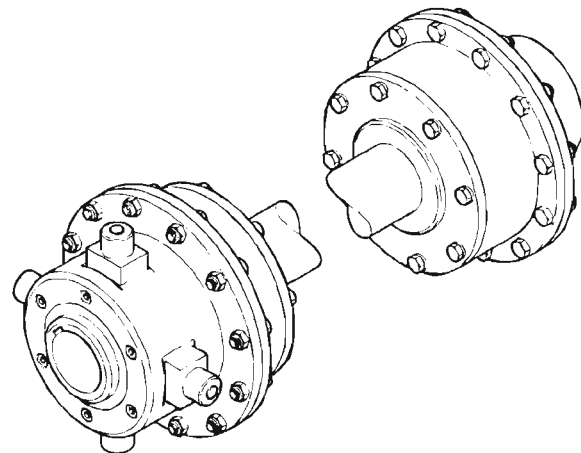

Combination with a torque limiting device to prevent damage to driving and driven machine under shock loads.

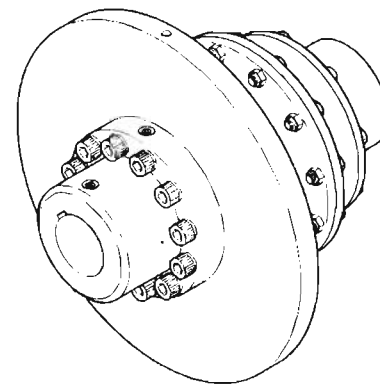

Coupling with a brake disc for use on cranes, fans and conveyor drives.

Selection Procedure

- From the continuous Power (P) and operating Speed (n) calculate the Application Torque T_{NORM} from the formula:

$$T_{NORM} = 9549 \times (P/n) \text{ Nm}$$

- Select Prime Mover Service Factor (Fp) from the table below.
- Select Driven Equipment Service Factor (Fm) from Page 15.
- The minimum Service Factor has been set at 1.5.
- Calculate T_{MAX} from the formula :

$$T_{MAX} = T_{norm} (Fp + Fm)$$

- Select Coupling such that $T_{MAX} < T_{kmax}$
- Check $n < \text{Coupling Maximum Speed}$ (from coupling technical data.)
- Check **Coupling Bore Capacity** such that $dmin < d < dmax$.
- Consult the factory for alternatives, if catalogue limits are exceeded.

N. B. If you are within 80% of maximum speed, dynamic balancing is required.

- T_{NORM} = Application Torque (Nm)
- T_{MAX} = Peak Application Torque (Nm)
- = Nominal Coupling Rating according to DIN 740 (kNm)
(with service factor = 3 according to Renold Hi-Tec Coupling standard)
- T_{KN} = Maximum Coupling Rating According to DIN 740 (kNm)
- p = Continuous Power to be transmitted by coupling (kW)
- n = Speed of coupling application (rpm)
- Fp = Prime Mover Service Factor
- Fm = Driven Equipment Service Factor
- dmax = Coupling maximum bore (mm)
- dmin = Coupling minimum bore (mm)



It is the responsibility of the system designer to ensure that the application of the coupling does not endanger the other constituent components in the system. Service factors given are an initial selection guide.

Prime mover service factors

Prime Mover Factors		FP
Diesel Engine	1 Cylinder	*
	2 Cylinder	*
	3 Cylinder	2.5
	4 Cylinder	2.0
	5 Cylinder	1.8
	6 Cylinder	1.7
More than	6 Cylinder	1.5
Vee Engine		1.5
Petrol Engine		1.5
Turbine		0
Electric Motor		0
Induction Motor		0
Synchronours Motor		1.5
Variable Speed*		
Synchronous Converter (LCI)	- 6 pulse	1.0
	- 12 pluse	0.5
PWM/Quasi Square		0.5
Cyclo Converter		0.5
Cascade Recovery (Kramer, Scherbius)		1.5

* The application of these drive types is highly specialised and it is recommended that Poona Couplings is consulted for further advice.

Selection Example

Product Range

- Selection of Induction Motor 800 KW at 1498 rpm driving a Rotary Pump.

P	=	800 kW	n	=	1498 rpm
dm	=	95 mm	dm	=	85 mm
temp	=	30°C	Fp	=	0
Fm	=	2			

$$T_{NORM} = (P/n) \times 9549 \text{ Nm}$$

$$= (800/1498) \times 9549 \text{ Nm}$$

$$= 5.1 \text{ kNm}$$

$$T_{MAX} = T_{NORM} (Fp + Fm)$$

$$= 5.1 (0+2) \text{ kNm}$$

$$= 10.2 \text{ kNm}$$

- The application requires a steel coupling (by customer specification) and PM type coupling should be selected. Examination of PM catalogue shows Pm12 as

$$T_{MAX} = 12 \text{ kNm}$$

which satisfies the condition

- $T_{MAX} < T_{kmax}$ (10.2 < 12.0) kNm
- $n < \text{Coupling Maximum Speed}$ (1498 < 3450) rpm
- $dmin < dp < dmax$ (72 < 95 < 109) mm
- $dmin < dm < dmax$ (72 < 85 < 109) mm

Transient Analysis

Calculated Examples

Illustrated below are two different types of transient torsional vibrations analysis that can be produced by Renold Hi-Tec Engineers.

This ensures optimum solutions are reached by the correct selection, of torsional stiffness and damping characteristics of the coupling.

Whilst the synchronous resonance and synchronous convertor (LCI) examples are shown, other applications which Renold Hi-Tec Couplings have experience of include, Torque Amplification, Electrical Speed Control Devices, PWM, Scherbius/Kramer, Short-Circuit and any re-connection of electrical circuits on the mechanical systems.

Example 1

Since June 1962 we have engineered flexible couplings for Synchronous Motor applications to reduce by damping, the damaging vibratory torques imposed into system when accelerating through the first resonant frequency.

Table A

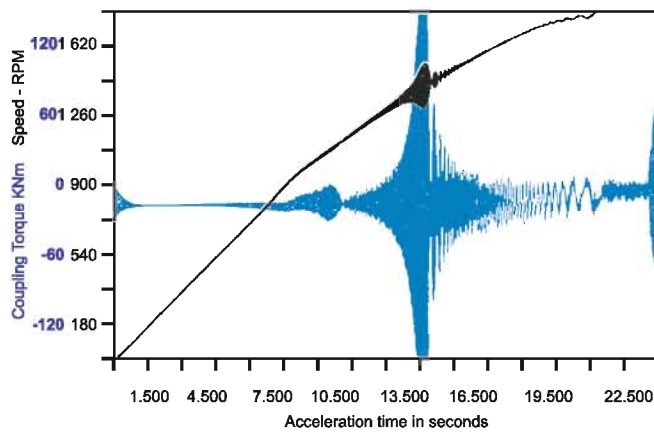

Table A shows vibrating torque experienced in the motor shaft when the system is connected rigidly (or by a gear or membrane coupling) to the driven system.

Table B

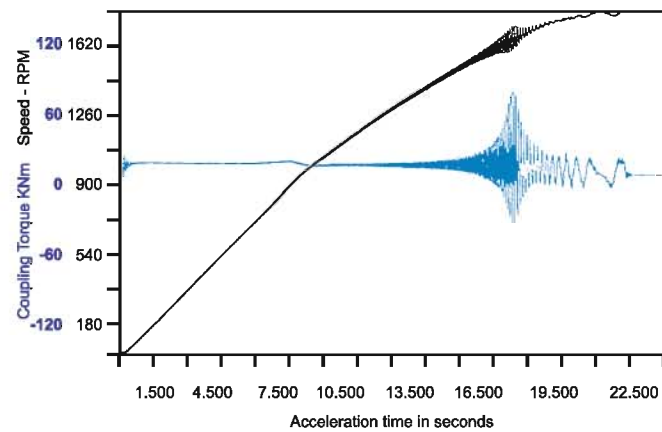

Table B shows the same system connected by DCB coupling. A PM type coupling is also used in such applications.

Example 2

We have been engineering flexible couplings for Synchronous Convertor (LCI) drives to control the forced mode conditions through the first natural frequency by judicious selection of torsional stiffness and damping.

Table C

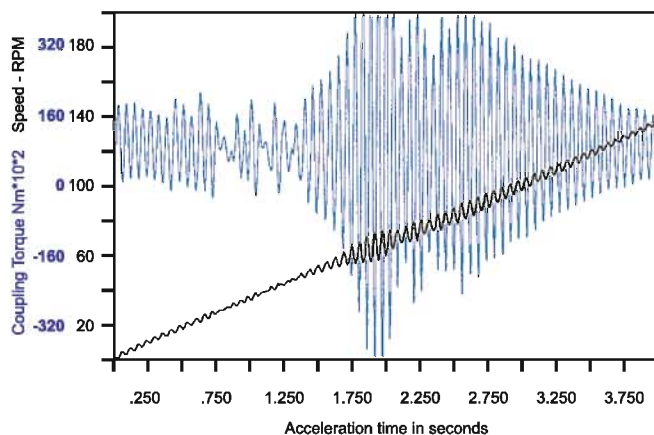

Table C shows a typical motor/fan system connected rigidly (or through a gear or membrane coupling) when damaging torques would have been experienced in the motor shaft.

Table D

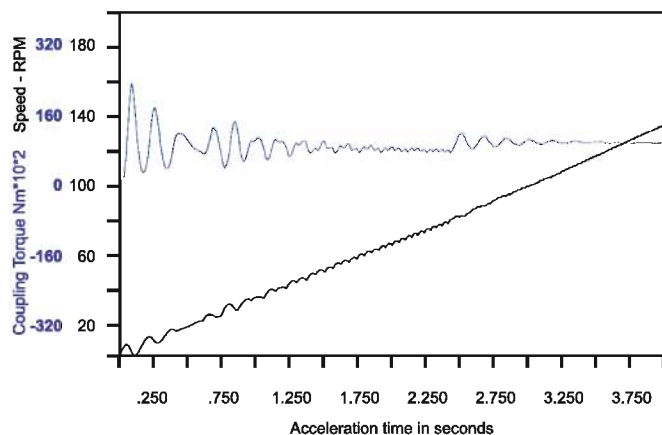

Table D shows the equivalent Renold Hi-Tec Couplings engineered solution using a PM coupling.

Damping Characteristics

Rubber

- Full laboratory control
- supported by a wide range of specialised equipment
- maintain high quality standards
- consistency in product performance.

Specialised compounds can be developed to meet specific requirements.

Standard compounds are listed below.

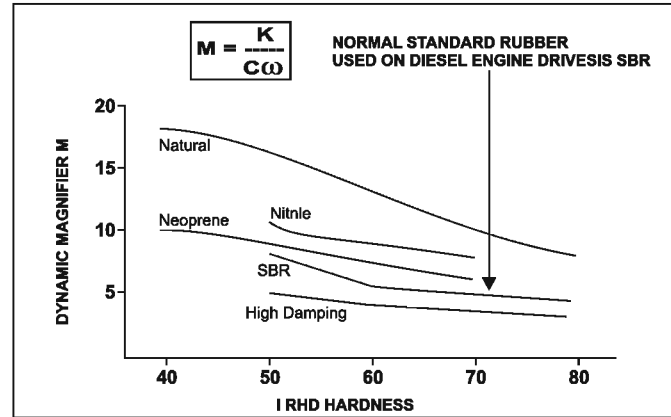

Rubber Compounds
Identification Lable
General Characteristics
Resistance to Compression Set Resistance to Flexing Resistance to Cutting Resistance to Abrasion Resistance to Oxidation Resistance to Oil and Gasoline Resistance to Acids Resistance to Water Swelling Service Temperature Max. Continuous Service Temperature Minimum

Natural	Styrene-Butadiene	Neoprene	Nitrile
Red (NM)	Green (SM)	Yellow (CM)	White (AM)
Good	Good	Fair	Good
Excellent	Good	Good	Good
Excellent	Fair	Good	Good
Excellent	Good	Good	Good
Fair	Fair	Very Good	Good
Poor	Poor	Excellent	Excellent
Good	Good	Fair	Fair
Good	Good	Good	Good
80°C	100°C	100°C	120°C
-50°C	-40°C	30°C	-40°C

Coupling damping varies directly with torsional stiffness and inversly with frequency for a given rubber grade. This relationship is conventionally described by the dynamic magnifier M, varying with hardness for the various rubber types.

$$M = \frac{K}{C\omega}$$

$$\text{Torque} = (k + ic\omega) ae^{i\omega t + \delta}$$

$$\text{Deflection} = ae^{i\omega t + \delta}$$

$$\tan \delta = \frac{C\omega}{K} = \frac{1}{M}$$

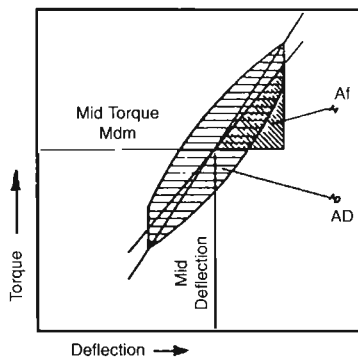

$$\psi = \frac{AD}{Af} = \frac{2\pi}{M}$$

This property may also be expressed as the Damping Energy Ratio or Relative Damping, ψ , which is the ratio of the damping energy, AD, produced mechanically by the coupling during a vibration cycle and converted into heat energy, to the flexible strain energy Af with respect to the mean position.

- Where
- C = Specific Damping (Nms/rad)
 - K = Torsional Stiffness (Nm/rad)
 - ω = Frequency (Rad/s)
 - M = Dynamic Magnifier
 - δ = Phase Angle Rad
 - ψ = Damping Energy Ratio

The rubber compound dynamic magnifier values are

Rubber Grade	M
NM 45	15
SM 50	10
SM 60	8
SM 70	6
SM 80	4

Driven Equipmen Service Factors

Application	Typical Driven Equipment Factor (Fm)	Application	Typical Driven Equipment Factor (Fm)	Application	Typical Driven Equipment Factor (Fm)
Agitators		Generators		- belt	1.5
Pune liquids	1.5	Alternating	1.5	- bucket	1.5
Liquide and solids	2.0	Not welding	1.5	- chain	1.75
Liquids - variable density	2.0	Welding	2.2	- screw	1.5
Blowers		Hammer mills		Dinthead	3.0
Centrifugal	1.5			Fan - ventilation	2.0
Lobe (Rootes type)	2.5	Lumber industry		Haulages	2.0
Vane	2.0	Barkers - drum type	3.0	Lump breakers	1.5
Brewing and Distilling		Edger feed	2.5	Pulverisor	2.0
Botting machinery	1.5	Live rolls	2.5	Pump - rotary	2.0
Lauter Tub	1.75	Log haul-incline	2.5	- ram	3.0
Briquetter Machines	3.0	Log haul-well type	2.5	- reciprocating	3.0
Can filling machines	1.5	Off bearing rolls	2.5	- centrifugal	1.5
Cane knives	3.0	Planer feed chains	2.0	Roadheader	2.0
Car dumpers	3.0	Planer tilting hoist	2.0	Shearer - Longwall	2.0
Car pullers - Intermittent Duty	2.5	Sawing machine	2.0	Winder Colliery	2.5
Clay working machinery	2.5	Slab conveyor	2.0	Mixers	
Compressors		Sorting table	2.0	Concrete mixers	2.0
Axial Screw	1.5	Trimmer feed	2.0	Drum type	2.0
Centrifugal	1.5	Metal Manufacture		Oil industry	
Lobe	2.5	Bar reeling machine	2.5	Chillers	2.0
Reciprocating - multi-cylinder	3.0	Crusher-ore	4.0	Oil well pumping	3.0
Rotary	2.0	Feed rolls	*	Paraffin filter press	2.0
Conveyors - uniformly loaded or fed		Forging machine	2.0	Rotary kilns	2.5
Apron	2.0	Rolling machine	*	Paper mills	
Assembly	1.5	Roller table	*	Barker-auxiliaries hydraulic	3.0
Belt	1.5	Shears	3.0	Barker-mechanical	3.5
Bucket	2.0	Tube mill (pilger)	*	Barking drum (Spur Gear only)	3.5
Chain	2.0	Wire Mill	2.0	Beater and pulper	3.5
Flight	2.0	Metal mills		Bleacher	2.0
Oven	2.5	Drawn bench-carriage	2.5	Calenders	2.0
Screw	2.0	Drawn bench - main drive	2.5	Chippers	2.5
Conveyors -uniformly loaded or fed		Forming machines	2.5	Coaters	2.0
Apron	2.0	Slitters	2.0	Converting machine (not cutters platers)	2.0
Assembly	1.5	Table conveyors - non-reversing	*	Couch	2.0
Belt	1.5	- reversing	*	Cutters, platers	3.0
Bucket	2.0	Wire drawing and flattening machine	2.0	Cylinders	2.0
Chain	2.0	Wire winding machine	2.0	Dryers	2.0
Flight	2.0	Metal rolling mills		Felt stretcher	2.0
Oven	2.5	Blooming mills	*	Felt whipper	2.0
Screw	2.0	Coilers-hot mill & cold mill	2.5	Jordans	2.25
Conveyors - heavy duty not uniformly fed		Cold mills	*	Line shaft	2.0
Apron	2.0	Cooling mills	*	Log haul	2.5
Assembly	2.0	Door openers	2.0	Presses	2.5
Belt	2.0	Draw benches	2.5	Pulp grinder	3.5
Bucket	2.5	Edger drives	2.5	Reel	2.0
Chain	2.5	Feed rolls, reversing mills	*	Stock chests	2.0
Flight	2.5	Furnace pushers	2.5	Suction roll	2.0
Oven	2.5	Hot mills	*	Washers and thickeners	2.0
Reciprocating	3.0	Ingot cars	2.0	Winders	2.0
Screw	3.0	Manipulators	3.0	Printing presses	2.0
Shaker	4.0	Merchant mills	*	Propellers	
Crane & hoists		Piercers	3.0	Marine - fixed pitch	2.0
All motions	3.0	Pushers rams	2.5	- controllable pitch	2.0
Crushers		Reel drives	2.0	Pullers	
Ore	3.0	Reel drums	2.0	Barge haul	2.5
Stone	3.5	Bar mills	*	Pumps	
Sugar (1)	3.5	Roughing mill delivery table	*	Centrifugal	1.5
Dredgers		Runout table	*	Reciprocating - double acting	3.0
Cable reels	2.5	Saws -hot, cold	2.0	single acting - 1 or 2 cylinders	3.0
Conveyors	2.0	Screwdown drives	2.5	3 or more cylinders	3.0
Cutter head drives	3.5	Skelp mills	*	Rotary - gear, lobe, vane	2.0
Jig drives	3.5	Slitters	2.0	Rubber industry	
Manoeuvering winches	3.0	Slabbing mills	*	Mixed - banbury	3.0
Pumps	3.0	Soaking pit cover drives	2.5	Rubber calender	2.0
Screen drive	3.0	Straighteners	3.0	Rubber mill (2 or more)	2.5
Utility winches	2.0	Table transfer & runabout	2.5	Sheeter	2.5
Dynamometer	1.5	Thrust block	3.0	Tyre building machines	2.5
Elevators		Traction drive	2.0	Tyre and tube press openers	2.0
Bucket	3.0	Tube conveyor rolls	2.0	Tubers and strainer	2.5
Centrifugal discharge	2.0	Unscramblers	2.5	Screens	
Escalators	1.5	Wire drawing	2.0	Air washing	1.5
Freight	2.0	Mills, rotary type		Grizzly	2.5
Gravity discharge	2.0	Ball	2.5	Rotary, stone or gravel	2.0
Fans		Cement kilns	2.5	Travelling water intake	1.5
Centrifugal	1.5	Dryers and coolers	2.5	Vibrating	2.5
Cooling towers	2.0	Kilns	2.5	Sewage disposal equipment	2.0
Forced draft	2.0	Hammer	3.5	Textile industry	2.0
Induced draft (without damper control)	2.0	Pebble	2.5	Windless	2.5
Feeders		Pug	3.0	* Use 1.75 with motor cut-out power rating	
Apron	2.0	Rod	2.5		
Belt	2.0	Tumbling barrels	2.5		
Disc	2.0	Mining			
Reciprocating	3.0	Conveyor - armoured face	3.0		
Screw	2.0				

PM Typical Applications



Steel mills. Medium section mill drive.



Conveyor drives.
Couplings fitted on belt conveyor drives.

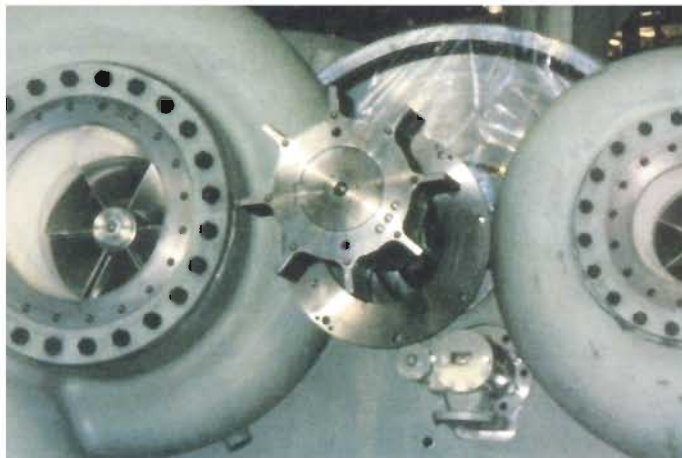

Compressor drives.
Coupling mounted between electric motor and compressor input shaft.



PM40 coupling on a Peter Brotherhood steam turbine generator.



Grinding mills.
Couplings fitted between electric motors, gearbox and mill.



PM18 and Pm27 coupling on a Halden-Robertson type 56 flying shear in Portugal.

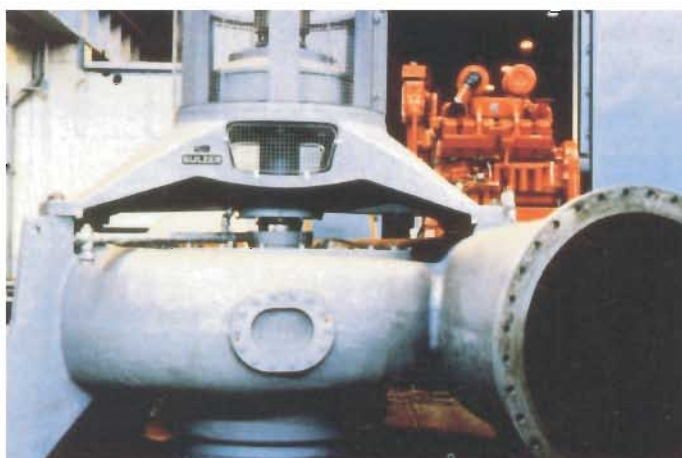

Pump sets.
Couplings fitted between electric motors and pumps.



PMO.7 brake drum coupling and a PMO.7 spacer coupling on a John Henderson coal charging car at BSC Dawes Lane.

Machining of HTB 40,000 I/M on CNC VMC 1700



Poona Couplings started as a joint venture between Ashok Mulye and Holset Engineering co. (Wholly owned subsidiary of Cummins USA) to manufacture their entire range of flexible couplings (0.4 kN to 600 kN). The company started commercial production in Sept. 86 and so far over 3,00,000 couplings have been supplied to satisfied customers all over the world. Holset's Coupling Division was acquired by Renold PLC in UK. Poona Couplings is now supplying couplings worldwide including Renold HiTec Couplings.

OTHER PRODUCT RANGE PRODUCED BY POONA COUPLINGS PVT. LTD.



TYPE RR



TYPE RB



TYPE DCB

POONA COUPLINGS PRIVATE LIMITED

REGISTERED OFFICE

49/A/4, Erandwane, Pune- 411 004 (INDIA).
TEL : (020) 25436471, 25420658.
FAX : (020) 25438837
Email : pc@vsnl.com

FACTORY

G.No. 106, Pirangut, Taluka Mulshi, Dist. Pune.
TEL : (020) 64730164, 64730165
FAX : (020) 20291076
Email : poonacouplings@vsnl.net

F:3014:00/03-2009

The Correct Solution